

## Engine support

### T10224

<b>en</b>	Original Instructions	<b>fi</b>	Alkuperäisten ohjeiden käännös	<b>pt-br</b>	Tradução das instruções originais
<b>de</b>	Originalbetriebsanleitung	<b>fr</b>	Traduction des instructions d'origine	<b>pt-pt</b>	Tradução das instruções originais
<b>ar</b>	ترجمة التعليمات الأساسية	<b>he</b>	תרגום ההוראות המקוריות	<b>ro</b>	Traducerea instrucțiunilor originale
<b>bg</b>	Превод на оригиналното ръководство за експлоатация	<b>hr</b>	Prijevod izvornih uputa	<b>ru</b>	Перевод оригинальной инструкции
<b>cs</b>	Překlad originálního návodu k použití	<b>hu</b>	Az eredeti útmutató fordítása	<b>sk</b>	Preklad pôvodného návodu
<b>da</b>	Oversættelse af de originale brugsanvisninger	<b>it</b>	Traduzione delle istruzioni originali	<b>sl</b>	Prevod originalnih navodil za uporabo
<b>el</b>	Πρωτότυπο εγχειρίδιο χρήσης	<b>ja</b>	元の手順の翻訳	<b>sr</b>	Prevod originalnih uputstava
<b>en_us</b>	Original Instructions	<b>ko</b>	원래 지침의 번역물	<b>sv</b>	Översättning av originalinstruktionerna
<b>es-es</b>	Traducción de las instrucciones originales	<b>lt</b>	Originalių instrukcijų vertimas	<b>tr</b>	Orijinal Talimatların Çevirisi
<b>es-mx</b>	Traducción de las instrucciones originales	<b>lv</b>	Originālo norādījumu tulkojums	<b>uk</b>	Переклад оригінальної інструкції
<b>et</b>	Originaalkasutusjuhendi tõlge	<b>nl</b>	Vertaling van de originele instructies	<b>zh-cn</b>	原始说明的翻译
<b>fa</b>	ترجمه دستورات اصلی	<b>no</b>	Oversettelse av de opprinnelige instruksjonene	<b>zh-tw</b>	原廠操作說明中譯本
		<b>pl</b>	Tłumaczenie oryginalnych instrukcji		

# 1 General Information

Product name:	Engine support
Product type:	Load holding device
Product number:	T10224
Weight:	9.6 kg
Max. load capacity:	365 kg
Static test coefficient:	3.0

## Intended Use:

- ▶ The engine support serves for holding the engine and gearbox unit of the 5 cylinder Diesel engine in the Transporter from 2004, in accordance with the workshop manuals of the Volkswagen Group brands.

## Terms of Use:

- ▶ Only for qualified workshop personnel.
- ▶ Only use the load holding device for work approved by the Volkswagen Group.
- ▶ Use only for loads up to 365 kg.
- ▶ Only use in connection with a suitable engine and gearbox jack (e.g. VAS 6931/V.A.G. 1383A) (see workshop manuals of the Volkswagen Group brands).
- ▶ Do not hold or lift any persons or animals.
- ▶ Do not hold or lift articles other than described in the workshop manuals of the Volkswagen Group brands.
- ▶ Do not stand under suspended loads.
- ▶ Only use on level, horizontal and weight-bearing ground.
- ▶ Only use in connection with the approved accessories (see workshop manuals of the Volkswagen Group brands).

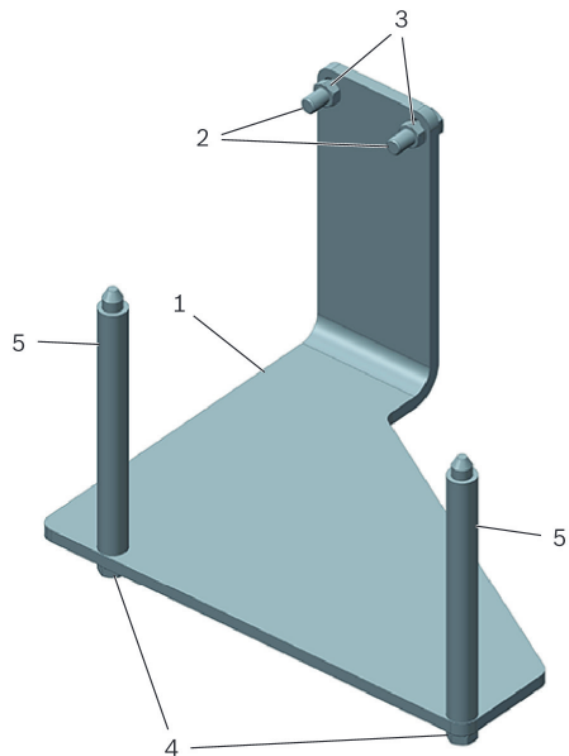

Figure 1: Engine support T10224

- 1** Base plate
- 2** Hexagon screws M10 x 25, 8.8 (2 pieces)
- 3** Hexagon nuts ISO 4032-M10-8 (2 pieces)
- 4** Hexagon screws M12 x 35, 8.8 and spring ring (2 pieces)
- 5** Bolts (2 pieces)

## 2 General Safety Instructions

### WARNING

#### Read and follow all safety notes and instructions!

Failure to follow the safety instructions may result in serious injuries and material damages.

Observe and follow the safety notes below.

- 
- ▶ The load holding device has been specifically constructed for its intended use. The safety of the load holding device can no longer be ensured if it is misused or modified in ways not expressly approved by the manufacturer. Serious injuries or damage to property can occur.
  - ▶ Ensure that each person using the load holding device is familiar with these instructions and can access them at all times.
  - ▶ Carefully read and adhere to the instructions in the technical safety information of the Volkswagen Group brands.
  - ▶ Wear safety shoes (according to ISO 20345, S2).
  - ▶ Wear protective gloves in order to avoid cuts.
  - ▶ Position hands and feet carefully to avoid potential crushing hazards.
  - ▶ Ensure that all users are also familiar with the operating manuals of all tools and workshop equipment, which are necessary for the work.
  - ▶ Use the load holding device only for work approved by the Volkswagen Group.
  - ▶ Use the load holding device only with the accessories approved by the Volkswagen Group.
  - ▶ Do not exceed the maximum load capacity of 365 kg.
  - ▶ Only use the engine support for engine and gearbox units in accordance with the workshop manuals of the Volkswagen Group brands.
  - ▶ Tighten the screw connections with the prescribed torque (see workshop manuals of the Volkswagen Group brands).
  - ▶ Only use in connection with a suitable engine and gearbox jack (e.g. VAS 6931/V.A.G. 1383A) (see workshop manuals of the Volkswagen Group brands).
  - ▶ The engine and gearbox jack may only be operated by one person.
  - ▶ The positioning of persons under the load and in the dangerous area is prohibited during the movement process.
  - ▶ Move the load slowly and carefully.
  - ▶ Observe the engine support and the load during all movements.
  - ▶ Only move the load on the lowest setting.
  - ▶ Ensure that the track is clear and easily visible.
  - ▶ Do not work on suspended loads.

### 3 Operating Instructions

1. Check the engine support for completeness, as well as visible damages such as signs of wear, deformation, breakages, cracks, and corrosion damages prior to each use. Check all threads for damages and ease of operation. Do not use the engine support when defects are noted and discard it immediately.
2. Carry out the necessary preparation work for the use of the engine support in accordance with the workshop manuals.
3. Place the engine support on the engine and gearbox jack and ensure that the reception bolt is inserted completely into the reception of the engine and gearbox jack and is secured.
4. Attach and secure the engine support to the engine and gearbox unit as described in the workshop manuals.

#### **WARNING**

##### **Danger through tilting or falling of the load!**

Incorrect attachment of the engine support to the load may cause a tilting or falling of the load! This can cause serious injuries and severe damage to materials.

- ▶ Attach the engine support exactly as described in the workshop manuals.
- ▶ Tighten the screw connections with the prescribed torque in accordance with the workshop manuals.

#### **WARNING**

##### **Risk of injury through moving loads!**

Crushing of limbs between load and vehicle can result from movements such as moving, lifting or lowering of the load.

- ▶ Position hands and feet in such a manner that crushing hazards do not exist when moving the gearbox.
- ▶ Observe the engine and gearbox jack as well as the load during all movements.

5. Carry out further work as described in the workshop manuals.
6. Secure the engine support against falling when demounting the engine support from the engine.
7. Ensure that all parts of the special tool have been removed after completing the repair work.

#### 3.1 Separating the engine from the transmission

#### **WARNING**

##### **Serious or fatal injuries through falling or tilting load!**

The load can topple or fall through insufficient securing. This could result in serious injuries and severe damage to materials.

- ▶ Secure the engine with a workshop crane and a suitable suspension device prior to separating the engine from the transmission!

1. Suspend a suitable suspension device approved by the Volkswagen Group on the hook of a workshop crane (e.g. VAS 6100) approved by the Volkswagen Group.



To adjust the centre of gravity of the loads to be picked up the suspension device must be positioned as described in the workshop manual.

2. Suspend and secure the load hooks in the eyelets at the engine.
3. Lift the arm of the workshop crane until the engine is secured by the workshop crane and the suspension device.
4. Dismount the gearbox as described in the workshop manuals.
5. Fix the engine when removing the engine support.
6. Ensure that all parts of the special tool have been removed after completing the repair work.

## 4 Inspection and maintenance

- ▶ Check the engine support for completeness, as well as visible damages such as signs of wear, deformation, breakages, cracks, and corrosion damages prior to each use. Check all threads for damages and ease of operation. Do not use the engine support when defects are noted and discard it immediately.
- ▶ Spare parts are available on request. Only use original replacement parts.
- ▶ Please contact your 1st level support representative with any queries.

### **NOTICE**

*Modifications to this product which have not been expressly approved by the manufacturer will void any warranty. The manufacturer assumes no liability for personal injuries or damages to materials which occur as the result of improper use of this product.*

---



## Declaration of Conformity with the Machinery Directive 2006/42/EC, Annex II 1A

Manufacturer:	Bosch Automotive Service Solutions GmbH Am Dörrenhof 1 85131 Pollenfeld-Preith Germany
Authorised to Compile the Technical Documents:	Bosch Automotive Service Solutions GmbH Am Dörrenhof 1 85131 Pollenfeld-Preith Germany
Product name:	Engine support
Product type:	Load holding device
Product number:	T10224

We hereby declare that each product described above complies with the relevant clauses of the 2006/42/EC Machinery Directive.

Any modification to a product not expressly approved by the manufacturer will void the validity of this declaration.

The following harmonised standards have been applied:

EN ISO 12100:2010	Safety of machinery - General principles for design - Risk assessment and risk reduction
EN 13155:2003+A2:2009	Cranes - Safety - Non-fixed load lifting attachments

Pollenfeld, 19 March 2018

Place, Date

Matthias Wagner, Managing Director

**Am Dörrenhof 1**

ETO

85131 Pollenfeld-Preith

Germany

**[www.bosch.com](http://www.bosch.com)**

2018-05-24