



Electronic measurement system for cam shaft adjustment



Translation of original instruction manual



?

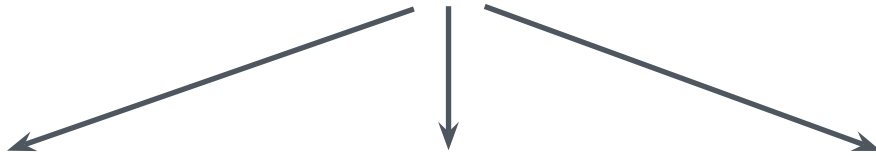

Owner's Manual



USB stick



1. Software
2. Owner's manual digital

Europe



Worldwide



www.tkr-support.com



1. Software updates
2. Download current owner's manuals
3. Support



Chapter	Page
1. Safety	
1.1 Information regarding this manual	4
1.2 Explanation of symbols	4
1.3 Markings	4
2. Scope of supply	
2.1 Scope of supply	5
2.2 Intended use	6
2.3 Technical specifications	6
2.4 Safety instructions	7
2.5 Principles for handling the electronic measurement system for cam shaft adjustment	8
2.6 Regular inspection and maintenance	8
2.7 Warranty	9
3. Technical specifications	
3.1 Technical data and device components	10
4. Application	
4.1 Preparing for startup	11
4.2 Startup – Assembly adapter ...	
4.2.1 EA 211, 3 and 4 cylinder TSI (without ACT)	12
4.2.2 EA 211, Evo 4 cylinder TSI ACT	13
4.4 Startup – Connecting sensor interface	14
4.5 Software installation and referencing	15
4.6 Attaching test tool VAS 611 007	16
4.7 Software operation	17
4.8 Firmware and software updates, Support	20
4.9 Spare parts	20
4.10 Troubleshooting	21
4.11 Stopping operation and storing the cam shaft tool	22
5. Service	
5.1 Disposal	22
5.2 Liability	22
5.3 Declaration of Conformity	23

The electronic measurement system for cam shaft adjustment is protected by patent. EPC Patent no. 17150522.5 - 1603

This owner's manual is protected by copyright. Any use outside of the boundaries of copyright law without the consent of the manufacturer is not permitted and is punishable by law. This also applies to the extraction of individual illustrations and the use of texts in excerpt form.

1.1 Information regarding this manual

State-of-the-art This tool is state-of-the-art technology. To ensure functionality, it must be operated in a proper and safe manner.

Technical modifications In the interests of quality assurance, we reserve the unrestricted right to implement technical modifications arising from further developments in technology and product improvements without prior notice.

Reading owner's manual Before using the tool, read the manual carefully and comply with it.

Handling All handling necessary to ensure correct operation is described in the owner's manual. No methods of working other than those approved by the manufacturer may be practiced.

1.2 Explanation of symbols

In this owner's manual, some sections use internationally known warning symbols, warning notes and general instruction symbols.

The individual symbols are explained below. Follow all instructions and safety rules.



Follow manual



High voltage!
Danger to life!



For more information, see section ...



Warning
General source of danger



Please note the following.



Arrow showing direction



Warning: Dangerous electric voltage



Arrow to clarify compression

1.3 Markings

Marking on the angle sensors

- | | | | |
|---|-------------------------------------|---|---------------|
| A | CE symbol | E | Item number |
| B | Warning | F | Voltage |
| C | UL certification | G | Serial number |
| D | QR code with item and serial number | | |



2.1 Scope of supply



VAS 611 007/1
Angle sensor

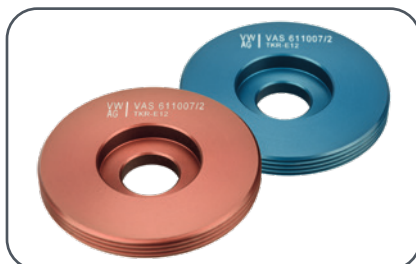

VAS 611 007/2
Locking ring



VAS 611 007/3
Clamping ring

Accessories EA 211, Evo 4 cylinder TSI ACT



VAS 611 007/4
Adapter for cam shaft housing
for EA 211, Evo 4 cylinder TSI ACT



VAS 611 007/5
Adapters for angle sensor, x2
for EA 211, Evo 4 cylinder TSI ACT

Accessories EA 211, 3 and 4 cylinder TSI (without ACT)



VAS 611 007/8
Adapter for cam shaft housing
for EA 211, 3 and 4 cylinder TSI (without ACT)



VAS 611 007/6
Adapter for cam shaft
for EA 211, Evo 4 cylinder TSI ACT, blue



VAS 611 007/7
Adapter for cam shaft
for EA 211, Evo 4 cylinder TSI ACT



VAS 611 007/9
Adapter for angle sensor
for EA 211, 3 and 4 cylinder TSI (without ACT),
blue



Owner's Manual
German/English



USB stick
with software for Windows 7 and 10 and
owner's manual in 37 languages
USB cable, 3 m



VAS 611 007/10
Adapter for cam shaft
for EA 211, 3 and 4 cylinder TSI (without ACT),
red

2.2 Intended use

Intended use The tool is used exclusively for checking and adjusting the timing on engines from Volkswagen AG.

Incorrect use When installing the electronic measurement system for cam shaft adjustment, make sure the technician connects the matching components in each case.
Consult the manufacturer before using the test device in certain (e.g. high humidity, salty, acidic or basic) atmospheres.
The measurement system is suitable for use at ambient temperatures between +5°C and +45°C.



If the electronic measurement system for cam shaft adjustment is defective, it must be put out of operation immediately.



Each cam shaft of the engine must only be adjusted with a module of the adjustment tool which is approved for it (see repair manual).



Use only USB cables shorter than 6 feet (3m).

2.3 Technical specifications

Model number	VAS 611 007
Operating temperature	+5°C (41°F) to +45°C (113°F)
Approved for	Engines from Volkswagen AG
EPC patent no.	17150522.5 - 1603



Color changes on the tool housings are material-related and do not represent a limitation on the quality or the function.

2.4 Safety instructions



The electronic measurement system for cam shaft adjustment is, in principle, only approved for the application for which the manufacturer has designed it.



Ensure that the tool is only operated by trained personnel instructed in its use.



Use of the tool by personnel who have not undergone the requisite training and instruction is prohibited.



Ensure that the owner's manual is made available to operating personnel. Before operating this device for the first time, each operator must read this owner's manual carefully. It must always be available where the product is being used. In addition to the instruction manual, the binding provisions of the accident prevention regulations applicable at the place of use and the general, accepted rules for safety compliance and professional working must be observed.



Route all supply lines in a manner that prevents people from tripping over them.



Observe the applicable occupational health and safety regulations of the respective country.



The tool must be visually inspected before each use.



The repair manual for the vehicle model concerned must be followed to adapt the measurement system to the cam shaft without causing damage. Incorrect assembly can cause damage to the cam shaft or result in measurement errors.



Never throw the tool or allow it to fall. Never misuse the tool or lend it to untrained personnel.



The safety instructions must be read and understood before any repair work is performed. Failure to read the instructions may result in serious bodily injury. No changes may be carried out to the electronic measurement system for cam shaft adjustment.



The manufacturer cannot accept liability for any conversion or modification of the electronic measurement system for cam shaft adjustment or for any resulting injury to persons or material damage.



An administrator account may be necessary to install the drivers.



Ensure that the software is only installed by trained personnel instructed in its use.

2.5 Principles for handling the electronic measurement system for cam shaft adjustment



Warranty

The manufacturer accepts no liability for damage caused by improperly performed repairs.



Improper use of the device that causes damage to equipment will invalidate the warranty.



Be careful when removing the angle sensors. The measurement tools must not bump into each other.

2.6 Regular inspection and maintenance



The inspection must be performed by qualified personnel. The electronic measurement system for cam shaft adjustment must be inspected at least once a year.

If the tool is used frequently, inspection must be performed at shorter intervals. The inspections are visual and functional where the condition of the parts is checked for damage, wear, corrosion or other changes and checked to make sure they are complete.



Repairs may only be performed by the manufacturer or by a person authorized by the manufacturer.



Surface damage must be repaired so as to prevent corrosion. The tool should be cleaned every six months or when required if very dirty.

The outside of the measurement device may be cleaned by the customer with a clean, lint-free, antistatic and dry cleaning cloth without abrasive or chemical cleaning agents which contain solvents. Do not use compressed air.

Inspections must be arranged by the operator.



2.7 Warranty

The electronic measurement system for cam shaft adjustment type VAS 611 007 is guaranteed for 24 months against defects in materials or workmanship.

The warranty begins on the date of delivery, as specified on the invoice or delivery note.

The warranty is valid for the user/customer as long as the tool is obtained from an authorized sales outlet and is used as described in the instructions and for the purposes for which it was designed.

The warranty becomes invalid if the tool is used for purposes other than the intended use.

In addition, the warranty becomes invalid if the tool is not used as described in the owner's manual.

In the event of defect or fault, TKR Spezialwerkzeuge GmbH will only repair or replace faulty parts at its own discretion.

Service address

TKR Spezialwerkzeuge GmbH

Service

Am Waldesrand 9-11

D-58285 Gevelsberg (Germany)

Phone +49 2332 66607-0

Fax +49 2332 66607-941

E-mail info@tkrgroup.com

3.1 Technical data and device components

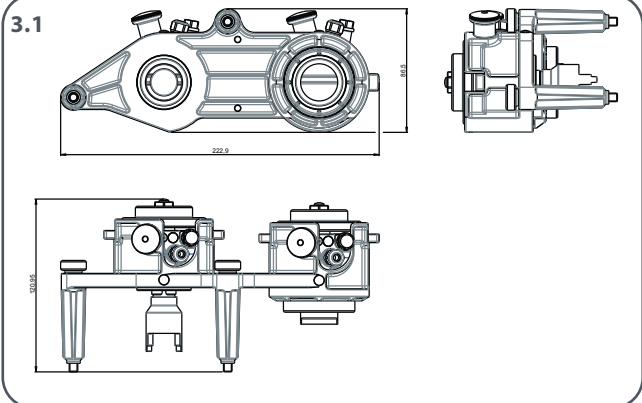

Technical data EA 211, 3 and 4 cylinder TSI (without ACT)

Width	222.9 mm
Height	86.5 mm
Depth	120.95 mm

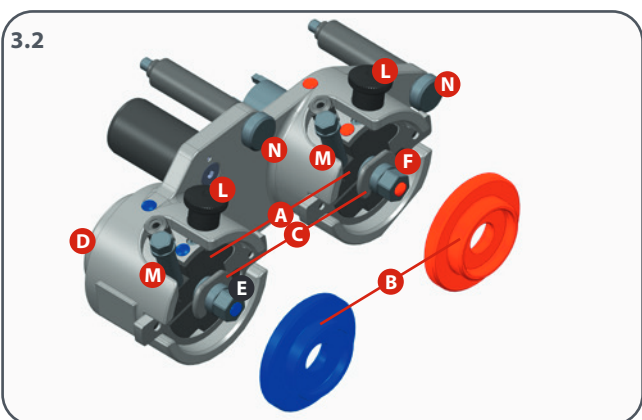

Device components EA 211, 3 and 4 cylinder TSI (without ACT)

- A VAS 611 007/1 Angle sensor
- B VAS 611 007/2 Locking ring
- C VAS 611 007/3 Clamping ring
- D VAS 611 007/8 Adapter for cam shaft housing
- E VAS 611 007/9 Adapter for cam shaft
- F VAS 611 007/10 Adapter for cam shaft
- L Locking pin
- M **Screw for brake**
- N Knurled screw EA 211

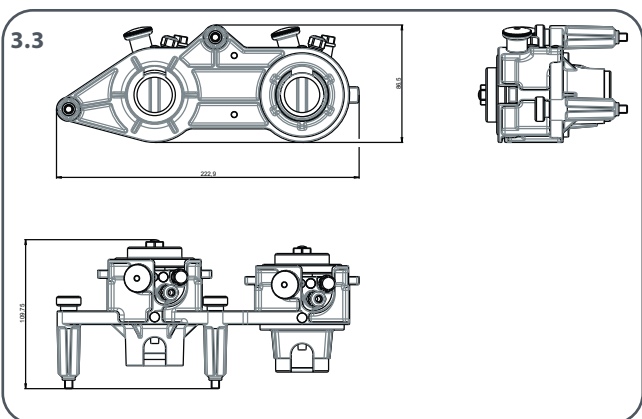

Technical data EA 211, Evo 4 cylinder TSI ACT

Width	222.9 mm
Height	86.5 mm
Depth	109.75 mm

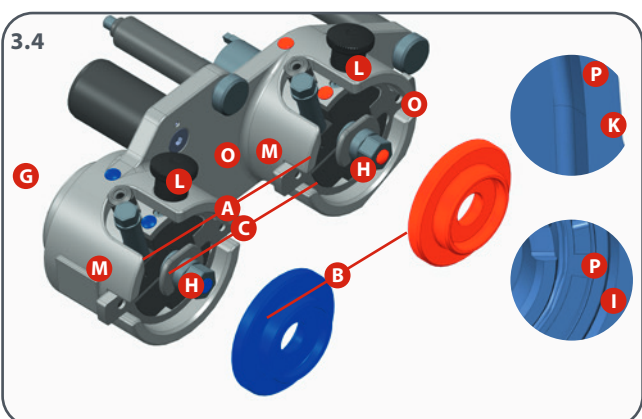

Device components EA 211, Evo 4 cylinder TSI ACT

- A VAS 611 007/1 Angle sensor
- B VAS 611 007/2 Locking ring
- C VAS 611 007/3 Clamping ring
- G VAS 611 007/4 Adapter for cam shaft housing
- H VAS 611 007/5 Adapter for angle sensor
- I VAS 611 007/6 Adapter for intake cam shaft
- K VAS 611 007/7 Adapter for exhaust cam shaft
- L Locking pin
- M **Screw for brake**
- O Knurled screw EVO
- P Threaded pin



Technical data sensor interface

Width	149.4 mm
Height	31.5 mm
Depth	64.9 mm



Use only USB cables shorter than 6 feet (3m).

USB connection sensor interface

Voltage	U: 5 VDC USB
Current	I max: 500 mA

3.1.5

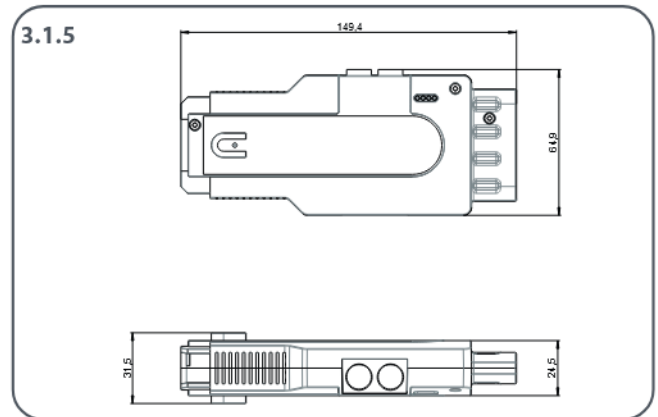

WLAN connection sensor interface*

Voltage	U: 12-48 VDC
Current	I max: 750 mA

*in preparation for future applications

4.1 Preparing for startup



Remove angle sensors individually! The measurement tools must not bump into each other!



Caution: Glass!
Do not throw or allow to drop.



Before installing the adapters for the cam shafts in the angle sensors, make sure the adapters are the correct ones for the angle sensors by checking the color identification.

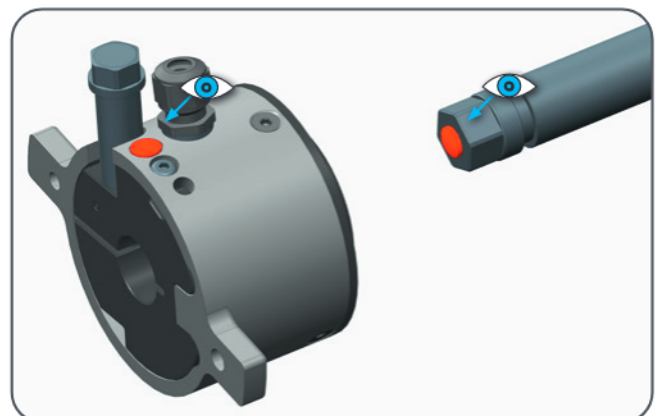

4.2.1 Startup – Assembly adapter EA 211, 3 and 4 cylinder TSI (without ACT)

4.2.1.1

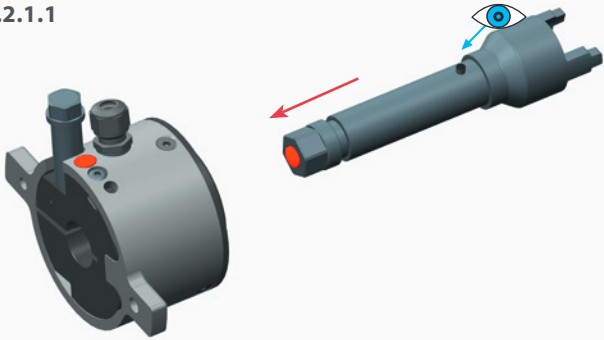

4.2.1.2

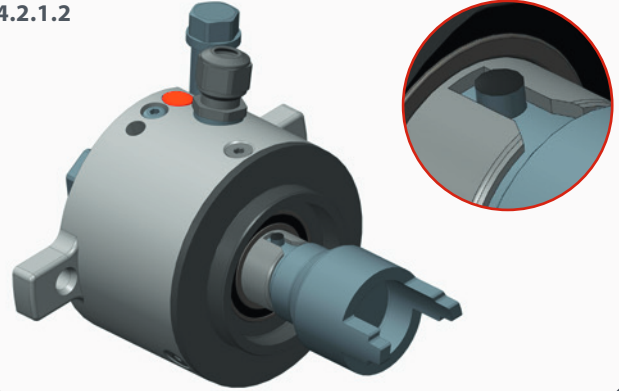

4.2.1.3

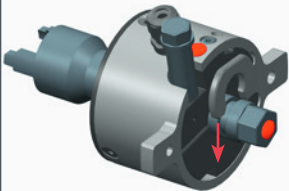

4.2.1.4

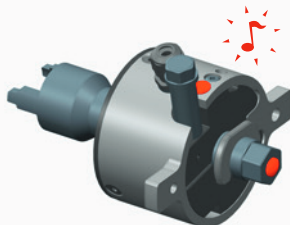

4.1

Preparing for startup



Check whether the brake is released.

4.2.1.1 / 4.2.1.2

Insert the adapter for the cam shaft housing VAS 611 007/8 into the angle sensor VAS611 007/1 up to the stop. When installing, check the position of the dowel pins and that the color coding is the same in each case. The adapter only fits in one position. It cannot be rotated. Do not use force.

4.2.1.3 / 4.2.1.4

Push the clamping ring VAS 611 007/3 into the groove until it clicks into place.

4.2.1.5

Insert the angle sensor marked red into the holder marked red in the adapter for the cam shaft housing VAS 611 007/8. Release the locking pins by pulling up, then insert the angle sensor and push it until the locking pin audibly engages. Repeat the procedure with the angle sensor marked blue.

4.2.1.5

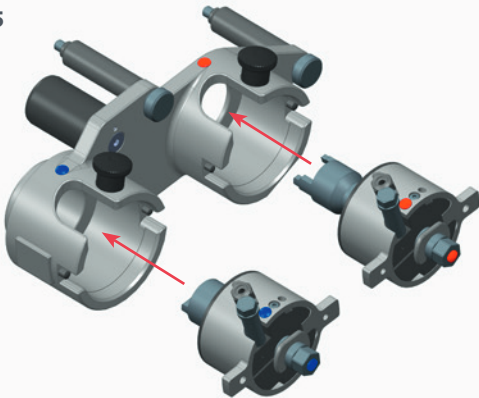

4.2.1.6

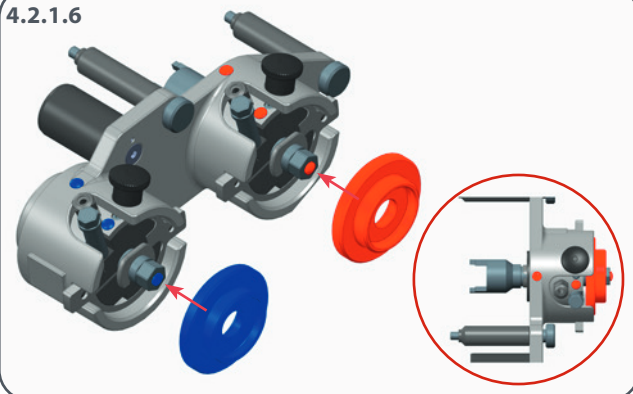

4.2.1.6

Screw in the associated colored locking rings VAS 611 007/2 with approx. 2 turns and check the adapter for the cam shafts VAS 611 007/9 and VAS 611 007/10 for freedom of movement.



4.4

Reference the adapter for the angle sensor before installing on the engine.

4.2.2 Startup – Assembly adapter EA 211, Evo 4 cylinder TSI ACT



4.2.2.1

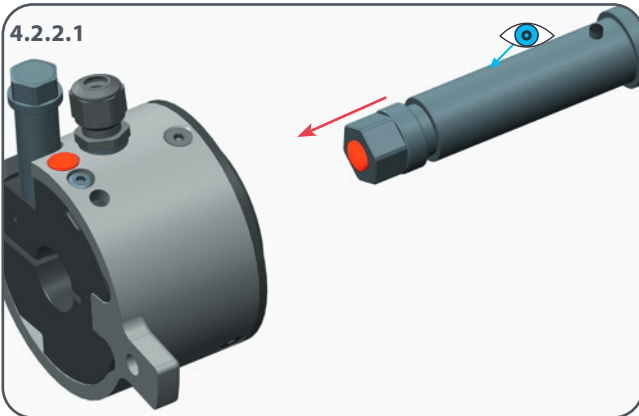

4.2.2.2

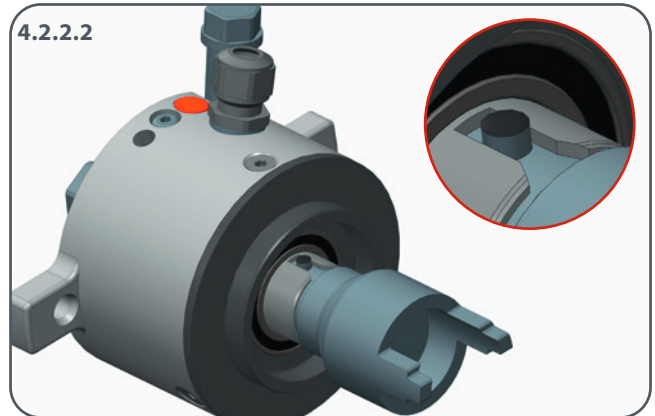

4.1

Preparing for startup



Check whether the brake is released.

4.2.2.1 / 4.2.2.2

Insert the adapter for the angle sensor VAS 611 007/5 into the angle sensor VAS611 007/1 up to the stop. When installing, check the position of the dowel pins and that the color coding is the same in each case. The adapter only fits in one position. Do not use force.

4.2.2.3 / 4.2.2.4

Push the clamping ring VAS 611 007/3 into the groove until it clicks into place.

4.2.2.5

Insert the red angle sensor into the holder marked red of the adapter for the cam shaft housing VAS 611 007/4. Unlock the locking pins by pulling up, then insert the angle sensor and push it until the locking pins audibly engage. Repeat the procedure with the angle sensor marked blue.

4.2.2.6

Screw in the associated colored locking rings VAS 611 007/2 with approx. 2 turns and check the shaft for freedom of movement. It must be possible to rotate the adapter for the angle sensor VAS 611 007/5 easily.



4.4

Reference the adapter for the angle sensor before installing on the engine.

4.2.2.3

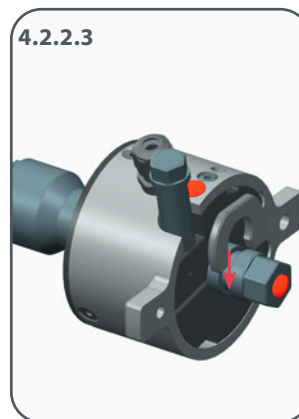

4.2.2.4

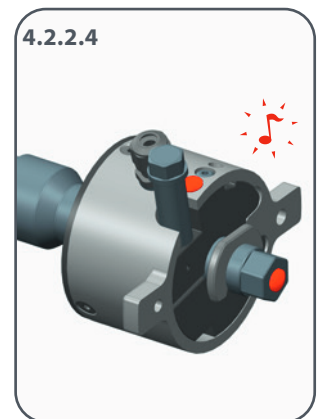

4.2.2.5

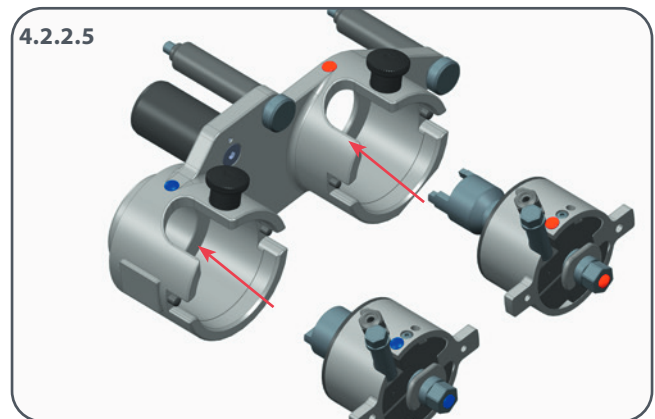

4.2.2.6

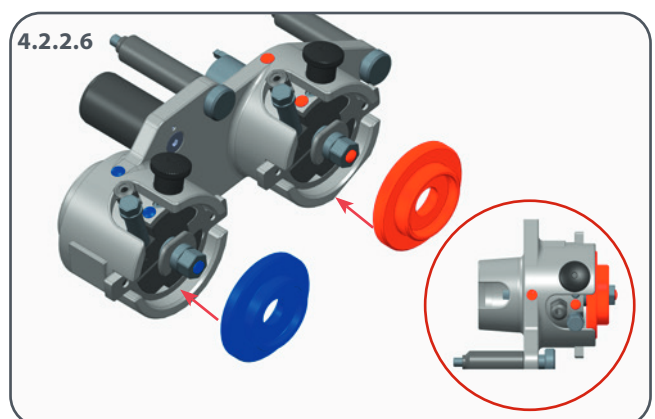

4.3 Startup – Connection sensor interface

4.3.1

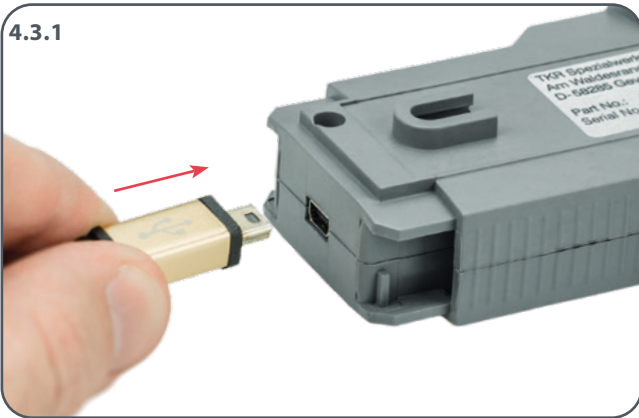

4.3.1

Using the USB lead contained in the scope of supply, connect the sensor interface to a free USB port on your PC.

4.3.2

To suspend the sensor interface in the engine compartment if necessary, push the hook provided into the holder of the sensor interface horizontally until it engages audibly.



Route all supply lines in a manner that prevents people from tripping over them.

4.3.2



Meaning of indicator lights



LED 1	LED 2	LED 3	LED 4
<input checked="" type="radio"/> Green: <input type="radio"/> Sensor detection module is ready for use	<input type="radio"/> Green flashing: <input checked="" type="radio"/> Data communication module is ready	<input type="radio"/> Red: <input type="radio"/> A serious error has occurred	<input type="radio"/> Blue: <input type="radio"/> WLAN connection* <input checked="" type="radio"/>
<input checked="" type="radio"/> Yellow: <input type="radio"/> Malfunction in the Sensor detection module	<input type="radio"/> Yellow: <input checked="" type="radio"/> Malfunction in the Data transfer module	<input type="radio"/> Yellow: <input type="radio"/> An error has occurred	<input type="radio"/> Green: <input type="radio"/> USB connection ready <input checked="" type="radio"/>
			<input type="radio"/> Orange: <input type="radio"/> No connection <input checked="" type="radio"/>
			<input type="radio"/> None: <input type="radio"/> Malfunction <input type="radio"/> <input type="radio"/>

*in preparation for future applications

4.4 Software installation and referencing



Admin rights are needed to install the software and the drivers.

4.4.1

Plug the USB stick provided into the USB port of your PC. Copy the "TKR_NW" folder to a location of your choice.



Required operating system:

Windows 7, Windows 10

Step 1. Install drivers

Windows 7 + Windows 10

- 1) Open the "TKR_NW" folder and run the appropriate file in the "Driver" folder:

„dpinst-amd64.exe“ → amd64 for a 64 bit system

„dpinst-x86.exe“ → x86 for a 32 bit System

Windows 10 only

- 2) Use the right mouse button to click on the Windows symbol and open Device manager.
- 3) Expand "ports (COM & LPT)".
- 4) Use the right mouse button to click on "Serial USB Device (COMxx)" and select "Update driver software".
- 5) Select "Browse my computer for driver software". Select "Let me select from a list of device drivers on my computer" and select "Remote NDIS6 based device". (If an error message appears after the installation, unplug and plug in the adjustment tool again (USB cable)).



Please also read the current "READ ME" file for the driver installation in the "Driver" folder.

4.4.1



The adjustment tool needs about 25-30 seconds before it is ready to use. Under "Network connections", a new LAN adapter must appear (Remote NDIS6 based device).

4.4.2

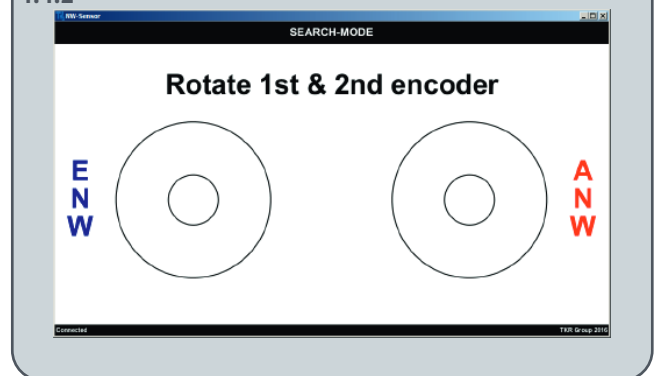

4.4.2

Step 2. Install software

Start the file "TKR_NW.exe" from the "TKR_NW" folder.



The sensor interface must be connected to the USB port to receive data.

4.4 Software installation and referencing

4.4.3

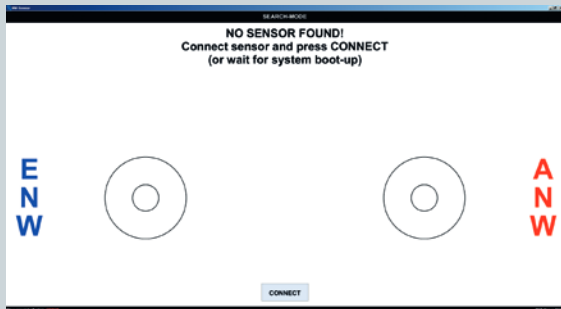

4.4.3

If the sensor interface is not connected via a USB cable, the message appears "NO SENSOR FOUND".

In this case, connect the sensor interface to your PC using a USB cable and press "CONNECT".

4.4.4

Now rotate the adapter for the exhaust cam shaft (ECS, red) 720° to the reference mark.

4.4.5

The sensor for the exhaust cam shaft is referenced when the confirmation "OK" appears on the display.

Now rotate the adapter for the intake cam shaft (ICS, blue) 720° to the reference mark. The sensor for the intake cam shaft is referenced when the "SEARCH MODE" changes to the "HOME" menu.



Both angle sensors must be referenced before each restart.

4.4.4



4.4.5

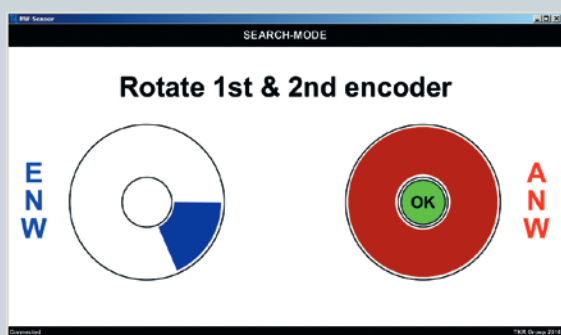

4.5 Attaching test tool VAS 611 007



Follow the repair manual of the relevant vehicle model for attaching the adapter for the cylinder head to the cam shaft module.

4.6 Software operation



4.6.1



Follow the repair manual of the relevant vehicle model for adjusting the timing.



4.7

Regularly check in our support portal to make sure you have the latest firmware and software. You will find the information in the display mode INFO.

4.6.1 Home screen

The *Home screen* opens automatically when both reference points have been found.

Available display modes:

MEASURE: Measurement

SHOW DB: Database view

INFO: Manufacturer specification / license / system information

If the angle sensors are not attached yet, follow the procedure:



4.4.3

Use the "HOME" button to exit from each submenu back into the *Home screen*.

4.6.2, 4.6.3 Display mode MEASURE

The angles from 0° to 180° and -180° to 0° are displayed with a pointer.

The last 3 measured values of the angles stored (see taskbar, Point 8) appear automatically. A new value is adopted by pressing the "DB", "TXT" or "NEXT" button.

4.6.2



4.6.3



Description of taskbar:

- 1 "Back" button / "Print" button
- 2 Engine no.
- 3 Engine type
- 4 Deletes text contents of fields
- 5 Writes data to database
- 6 Writes data to text file
- 7 Writes values to "Short History"
- 8 Display of last three angle measurements
- 9 Brake symbol

4.6 Software operation

4.6.3

ID	Motor Number	Motor Type	ENW	ANW	Date	Time
00062	Test	1234	0.0°	-3.3°	2016.11.22	08:35:14
00062	AA	AA	2.1°	-4.5°	2016.11.18	14:29:28
00061	unknown	unknown	2.1°	-5.5°	2016.11.18	14:27:33
00060	unknown	unknown	6.7°	-2.4°	2016.11.18	14:27:11
00059	unknown	unknown	5.2°	-3.7°	2016.11.18	14:26:39
00058	unknown	unknown	-180.0°	0.0°	2016.11.18	14:09:48
00057	unknown	unknown	-180.0°	0.0°	2016.11.18	14:09:47
00056	unknown	unknown	-180.0°	0.0°	2016.11.18	14:09:44
00055	unknown	unknown	-180.0°	0.0°	2016.11.18	14:09:41
00054	unknown	unknown	-180.0°	0.0°	2016.11.18	14:09:35
00053	unknown	unknown	0.0°	0.0°	2016.11.18	14:08:52
00052	unknown	unknown	-180.0°	0.0°	2016.11.18	14:08:51
00051	unknown	unknown	-180.0°	0.0°	2016.11.18	14:08:53
00050	unknown	unknown	-180.0°	0.0°	2016.11.18	14:08:52
00049	unknown	unknown	-180.0°	0.0°	2016.11.18	14:06:59
00048	unknown	unknown	-180.0°	0.0°	2016.11.18	14:03:36
00047	unknown	unknown	-180.0°	0.0°	2016.11.18	14:03:33
00046	unknown	unknown	-180.0°	0.0°	2016.11.18	14:02:22
00045	unknown	unknown	-180.0°	0.0°	2016.11.18	14:02:21
00044	unknown	unknown	-180.0°	0.0°	2016.11.18	14:02:16
00042	unknown	unknown	-180.0°	0.0°	2016.11.18	14:02:14
00042	unknown	unknown	-180.0°	0.0°	2016.11.18	14:02:13
00041	unknown	unknown	-180.0°	0.0°	2016.11.18	14:02:13
00040	unknown	unknown	79.9°	-49.6°	2016.11.18	12:34:31
00039	unknown	unknown	79.9°	-27.6°	2016.11.18	12:34:23

4.6.3 SHOW DB

The last 25 entries appear in the database.

If there is still no database in the program folder, one is created automatically. A connection is automatically made to an existing database.

If no value has been entered in the text fields "Engine Number" and "Engine type", "unknown" is entered in these fields automatically.



4.6.2

Description of taskbar

4.6.4

```

1 000 unknown unknown -162.2 -103.5 22.11.2016 08:49:55
2 001 unknown unknown -189.3 +018.0 22.11.2016 08:44:00
3 002 unknown unknown -012.4 -004.2 22.11.2016 08:44:05
4 003 unknown unknown -012.4 -004.2 22.11.2016 08:44:07
5

```

4.6.4 TXT taskbar

A new file is created in text format in the document folder for each session (with Time/Date Stamp), otherwise data are always written to the same file:

C:\Users\Username\Documents\TKR-NW-Sensor-Data

If no value has been entered in the text fields "Engine Number" and "Engine type", "unknown" is entered in these fields automatically.



4.6.5 – 4.6.7 Brake

A mechanical brake is integrated in each adapter to arrest the cam shaft during adjustment; tightening the screw for the brake (see 3.1, M) stops the adapters from moving.

Tighten the screw for the brake (see 3.1, M) to 10 Nm to apply the brake.

Torque wrench with 10 AF socket.



The brake must not be applied without the adapter under any circumstances.



The brake must be released in order to check or adjust the timing. The brake display must not flash yellow or red.

The brake symbol must be green (see 4.6.5).



Please follow the repair manual of the relevant vehicle model on how to operate the brake.

The display shows the degree to which the brake is applied:

- | | | |
|-------|------------------------------|------------------|
| 4.6.5 | Brake released: | green |
| 4.6.6 | Brake applied: | yellow, flashing |
| 4.6.7 | Brake applied hard (~10 Nm): | red, flashing |



The symbol is not to be used as a substitute for a torque wrench.

You must always use a torque wrench to ensure compliance with the technical specifications of the repair manual during the adjustment. The colored symbolic display must therefore only be regarded as an aid and must not be used as a torque measurement device.

4.6.5



4.6.6

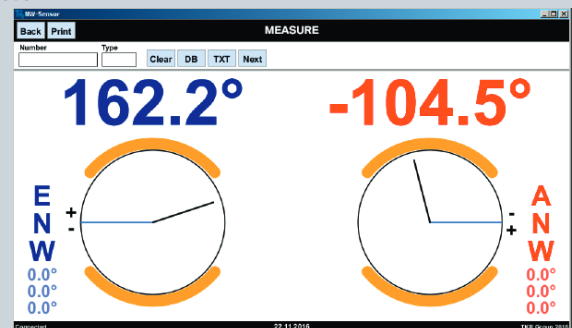

4.6.7

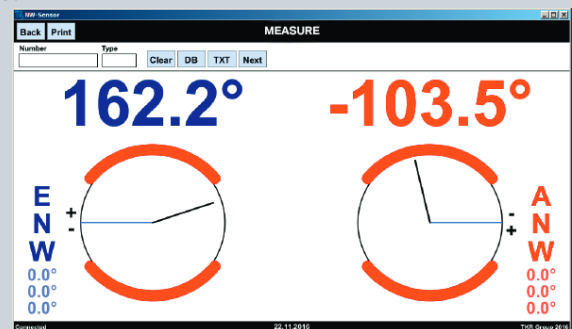

4.7 Firmware and software updates, Support

4.7.1

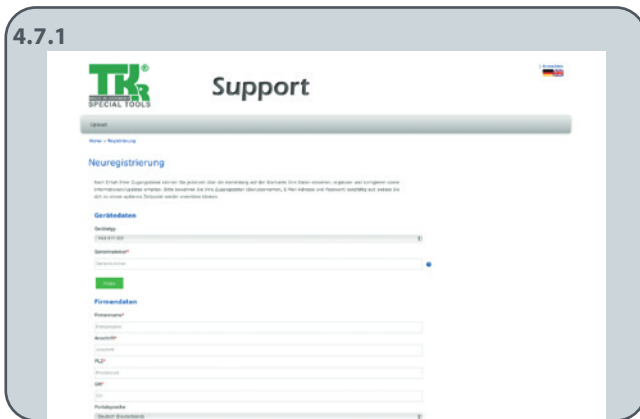

4.7.1 Registration

Register your electronic measurement system VAS 611 007 on the Internet page:

www.tkr-support.com

After registering, you will be automatically sent a password to use to log in again in the future.

4.7.2 Download

4.7.2

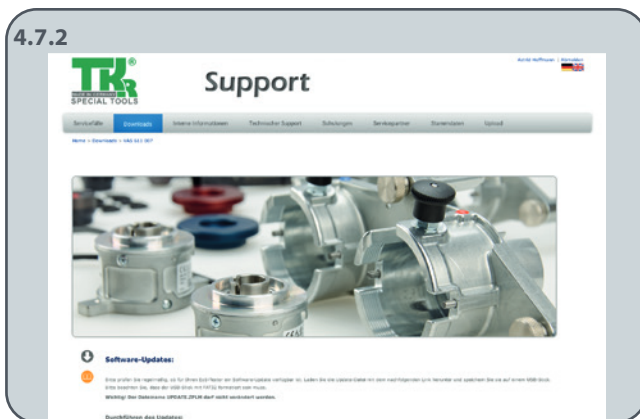

To check the current status of your firmware and software, log in, change to the menu option Download and select tool VAS 611 007. Compare the version numbers that appear with the information displayed in the display mode INFO.

Follow the relevant instructions for updating in our support portal.

4.8 Spare parts

USB connection sensor interface

Item number	Designation	Description	pc.
VAS 611 007/1	Angle sensor		1
VAS 611 007/2	Locking ring	red, blue	2
VAS 611 007/3	Clamping ring		4
VAS 611 007/4	Adapter for cam shaft housing	EA 211, Evo 4 cylinder TSI ACT	1
VAS 611 007/5	Adapter for angle sensor	EA 211, Evo 4 cylinder TSI ACT	1
VAS 611 007/6	Adapter for intake cam shaft	EA 211, Evo 4 cylinder TSI ACT	1
VAS 611 007/7	Adapter for exhaust cam shaft	EA 211, Evo 4 cylinder TSI ACT	1
VAS 611 007/8	Adapter for cam shaft housing	EA 211, 3 and 4 cylinder TSI (without ACT)	1
VAS 611 007/9	Adapter for cam shaft	EA 211, 3 and 4 cylinder TSI (without ACT)	1
VAS 611 007/10	Adapter for cam shaft	EA 211, 3 and 4 cylinder TSI (without ACT)	1



4.9 Troubleshooting

Although our electronic measurement system for cam shaft adjustment is reliable, problems and malfunctions may occur. You can easily repair the faults described below:

You must follow the safety instructions!

Regularly check in our support portal to make sure you have the latest firmware and software. You will find the information in the display mode INFO.

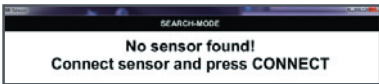
Malfunction	Problem	Remedy	Section
After the software has started, the following message appears: 	The sensor (sensor interface) is not connected to the PC via USB.	Connect box to the PC via the USB and press the "CONNECT" button. Install the drivers.	4.3 4.4
	The system is not ready for use yet (system is still starting).	Wait 25-30 seconds if necessary. Check Network connections under Windows.	4.4
Although several sensors (sensor interfaces) are connected to the PC, only one sensor operates.	The software can only communicate with one sensor (sensor interface). The software uses the first sensor it finds. The other sensors are ignored.	Only connect one sensor (angle sensor box) to the PC at a time.	4.3
In the search mode, no "OK" message appears (for one or both angle sensors) although the circuit is complete.	The angle sensor is defective.	Replace the defective angle sensor(s).	4.2.1 / 4.2.2
During a series of measurements, the angle values and angle charts no longer change.	The USB cable from the sensor interface has become disconnected from the PC during a series of measurements.	Remove the adapter for the cylinder head from the cam shaft module. Plug the USB cable into the PC and re-start the software.	see Repair manual
The values and charts no longer change in Search Mode/Measure Mode. The sensor has been found ("Connected").	The angle sensor is defective.	Replace the defective angle sensor(s).	4.2.1 / 4.2.2
The brake does not respond (permanently green).	Angle sensor/brake is defective.	Replace the defective angle sensor(s)/brake(s).	4.2.1 / 4.2.2
	Angle sensor/brake is dirty.	Clean the defective angle sensor(s)/brake(s).	2.6
The brake does not change to "red" (10 Nm).	Torque is less than 10 Nm.		see Repair manual
	Angle sensor/brake is dirty or defective.	Replace or clean the defective angle sensor(s)/brake(s).	4.2.1 / 4.2.2
The brake does not change to "yellow" (hand tight).	Brake is too slack.	Tighten the brake more firmly.	
	Angle sensor/brake is dirty or defective.	Replace or clean the defective angle sensor(s)/brake(s).	4.2.1 / 4.2.2
LED 3 of the E box appears red.	A serious error has occurred.	Unplug the sensor from the USB port and re-connect it.	4.4
LED 3 of the E box appears yellow.	An error has occurred.	Unplug the sensor from the USB port and re-connect it.	4.4

4.10 Completing an operation and storing the cam shaft tool

Before and after each operation, check the tool for any damage.
All parts should be cleaned before storing them.



Always clean the tool before storing and store it in a safe place. Avoid contamination.

5.1 Disposal



Machinery, equipment and their components must be disposed of as prescribed by the laws, regulations and other provisions of the country in which they are located.

We recommend that disposal be entrusted to licensed professional operators.

5.2 Liability



Neither this limitation of liability or other parts of this instruction manual relieves the TKR Group from liability in the case of death or injury to a person through the negligent or deliberate action of the TKR Group or its employees, representatives, agents or vicarious agents if such exclusion is not permissible by law.

However, taking the above clause duly into account, in each legally admissible case the maximum possible sum that may be claimed from TKR Group is restricted to USD 50. This applies irrespective of the legal basis for the claim. The existence of more than one basis for the claim or claims does not increase this amount.

Irrespective of this, however, TKR does not otherwise bear liability – on whatever legal grounds – for:

- loss of income or profit,
- loss of reputation, commercial expectations or company goodwill,
- loss of or damage to equipment, machinery or other items or resources used in connection with the cam shaft tool.
- any indirect or consequential damages stemming from a negligent or deliberate act on the part of the TKR Group or its employees, representatives, agents or agents, or poor performance of the contract, to the extent permitted by law.

Apart from the expressly assured properties, TKR provides no warranty on any further properties of any kind, neither directly nor indirectly, nor tacitly.

The place of jurisdiction for all claims against the TKR Group is its headquarters.

EU Declaration of Conformity

For the purposes of the low-voltage directive
2014/35/EU

Manufacturer: TKR Spezialwerkzeuge GmbH
Am Waldesrand 9–11
58285 Gevelsberg, Germany

Contact: Thorsten Weyland, Technical Director,
Technical documentation

Designation: Test device

Tool type: Electronic measurement system for cam shaft
adjustment

Developed and constructed in accordance with the
standards and guidelines listed by

TKR Spezialwerkzeuge GmbH
Am Waldesrand 9–11
DE-58285 Gevelsberg (Germany)

Harmonized standards German Product Safety Act(ProdSG)
applied: IEC 61326-1:2012
IEC 61010-1:2010

Serial number range: 00001 – 99999

Low-voltage guideline: 2014/35/EU

As manufacturer, we declare: The products marked accordingly fulfill the requirements
of the directive and standards listed.

Thorsten Weyland

Gevelsberg, 10.03.2017 Thorsten Weyland
Technical Director

Am Waldesrand 9-11
D-58285 Gevelsberg (Germany)

Phone +49 2332 66607-0
Fax +49 2332 66607-941
E-mail info@tkrgroup.com
Web www.tkrgroup.com